

«STS-GeoService» LLC

RESEARCH AND PRODUCTION COMPANY



EFFECTIVE OIL AND GAS FIELD
DEVELOPMENT USING MODERN
EQUIPMENT AND TECHNOLOGIES

ABOUT COMPANY

«STS-GeoService» LLC takes a leading position in a well intensification using high energy methods

Employee experience is more than 20 years

The company employs specialists with high experience in oil and gas industry



UNIQUE TECHNOLOGIES

Unique method of gas-dynamic fracturing, which has no analogues. Complex impact technology "URAGAN" and Plug-and-Perf



MODERN EQUIPMENT

A wide range of perforation systems, pipe cutters, packers, perforator-generator and etc.



RELIABLE REPUTATION

High quality and reliability are confirmed by leading oil companies



PRODUCTION

Own production facilities certified according to the ISO:9001



SPECIAL NETWORK OF WAREHOUSES STORING THE EQUIPMENTS

Wide network safe storage warehouses; prompt equipment supply

WE OFFER EFFECTIVE METHODS FOCUSING ON SOLVING EACH CUSTOMER'S PROBLEMS

www.sts-geo.com

GDK-170 TECHNOLOGY

The use of GDK-170 pressure generator allows to increase the permeability of the bottom zone due to the formation and reposition effect

THE MAIN INTENSIFICATION METHODS

The ratio of the main geological and technical measures in the intensification market, %

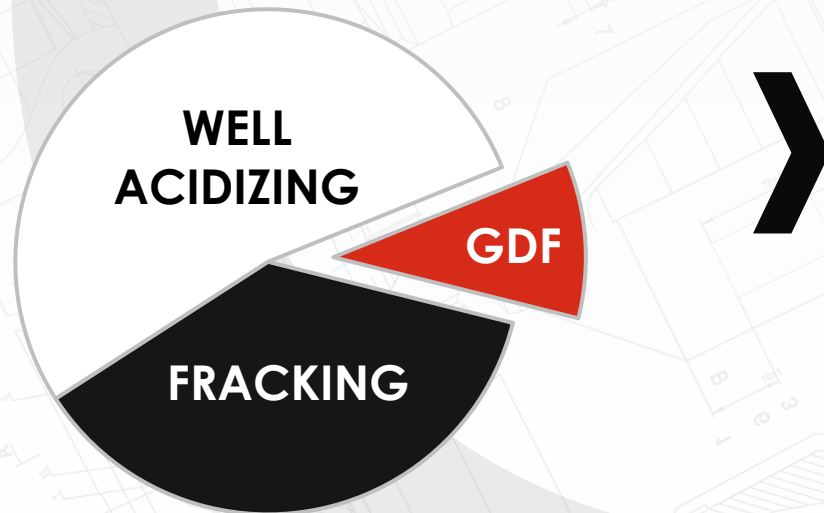

UNIQUE PATENTED TECHNOLOGY OF PRODUCTION / INJECTIVITY INTENSIFICATION OF VARIOUS WELLS

- 1** • INCREASING PRODUCTIVITY OF PRODUCTION WELLS
- 2** • ENLARGEMENT THE INJECTION CAPACITY OF INJECTION WELLS
- 3** • LEVELING THE INJECTION PROFILE
- 4** • CLARIFICATION THE POTENTIALITY OF EXPLORATION WELLS
- 5** • OBTAINING STABLE HYDRODYNAMIC CONNECTION WITH THE FRACKED FORMATION
- 6** • CONDUCTING THE INTENSIFICATION FOR PRODUCTIVITY/INJECTIVITY IN HORIZONTAL WELLS

GDF TECHNOLOGY

Implementation of gas-dynamic fracturing technology using the GDK-170 pressure generator that increases the permeability of the formation

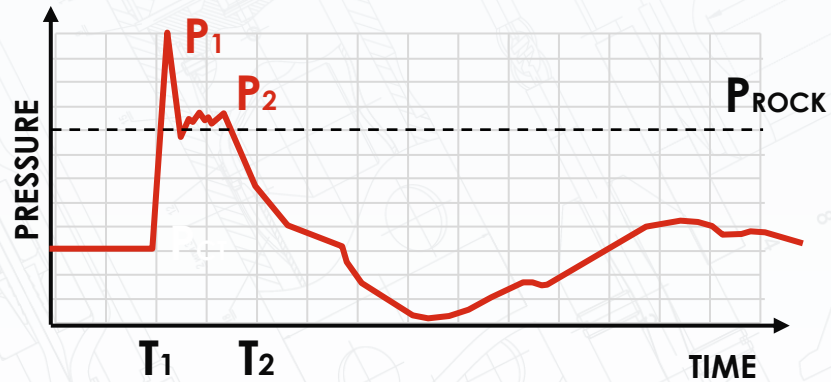

P_{ROCK} – ROCK PRESSURE
 P_1 – FRACTURE PRESSURE
 P_2 – PRESSURE CREATED BY THE BURNING OF MAIN CHARGES

GDK-170 INCREASES THE PERMEABILITY OF THE FORMATION DUE TO THE:

- CRACK NETWORK FORMATION
- THERMAL EFFECT
- CLEANING THE FORMATION DUE TO MULTIPLE PRESSURE RELIEFS

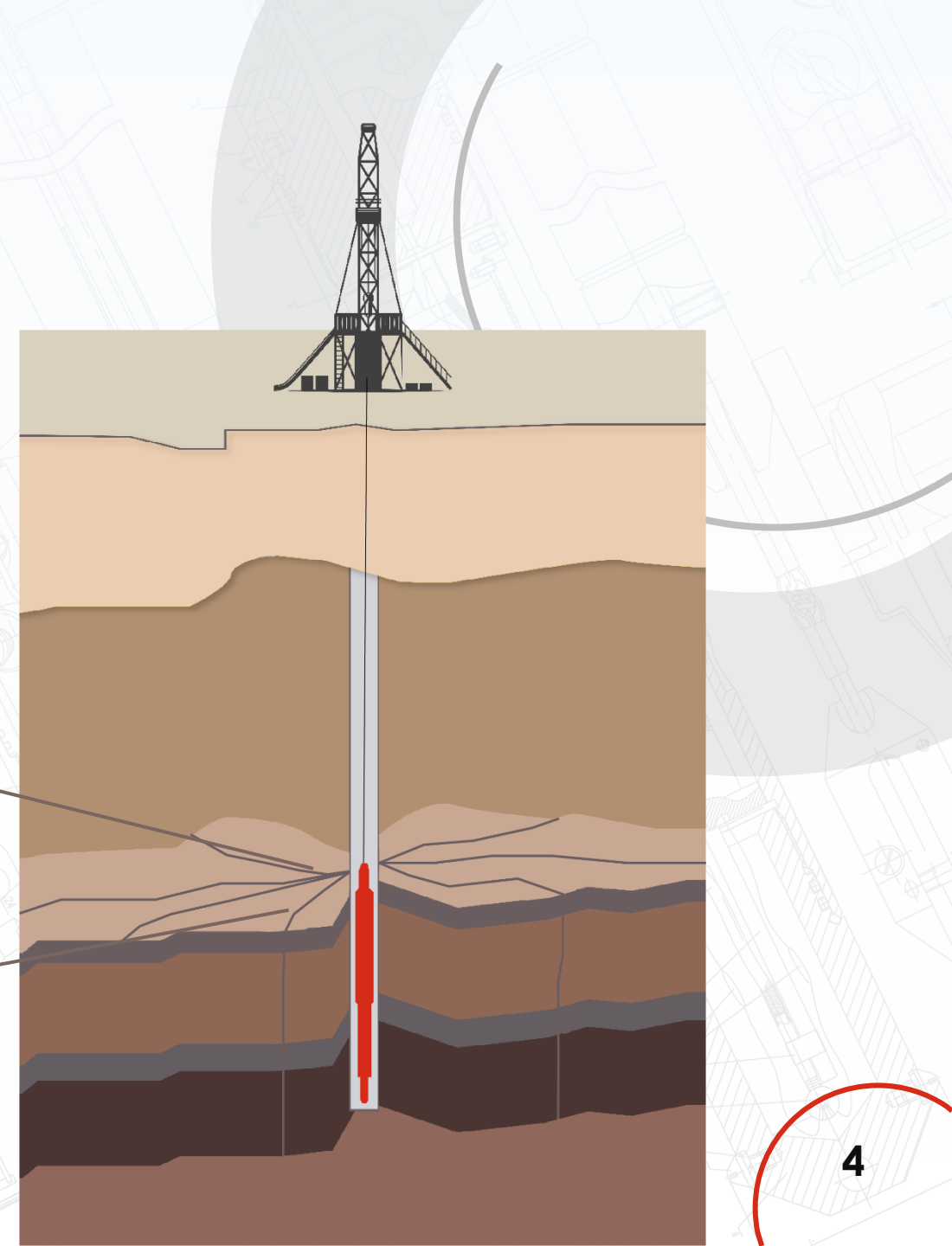
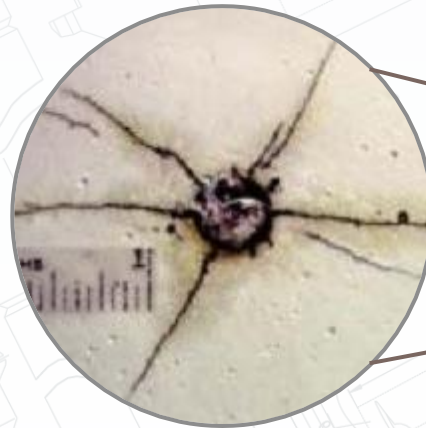

GDK-170 GAS GENERATOR CONSTRUCTION

The design schematic of the generator lowered by logging cable

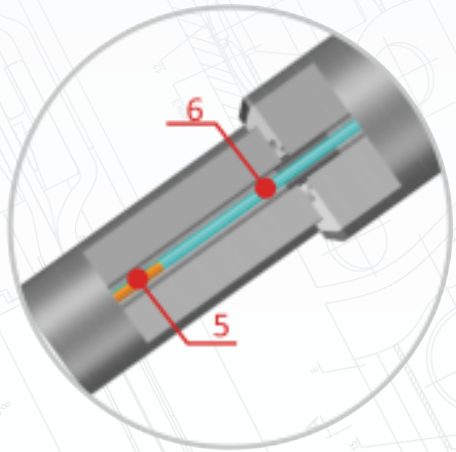
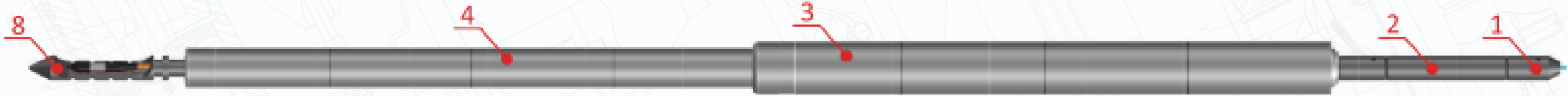

VOLUMETRIC AND
LAYERWISE COMBUSTION
MODES

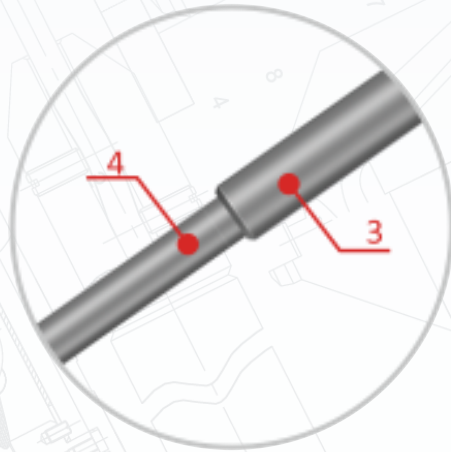

USE VARIOUS SIZES OF
CHARGES TO CONTROL
THE ACTION POWER AND
DURATION

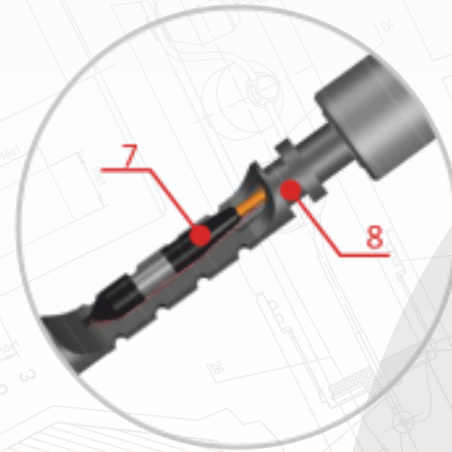

GAS GENERATOR IS INITIATED
BE BLASTING CARTRIDGE
THROUGH THE DETONATION
CORD

- 1 CONE
- 2 WEIGHTS
- 3 THE MAIN CHARGES
- 4 THE IGNITING CHARGES
- 5 DETONATING CORD
- 6 LOGGING CABLE
- 7 BLASTING CARTRIDGE
- 8 CONE

GDK-170 GAS GENERATOR CONSTRUCTION

The design schematic of the generator lowered by tubing

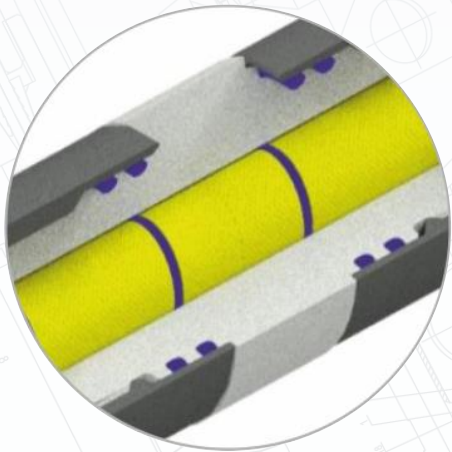
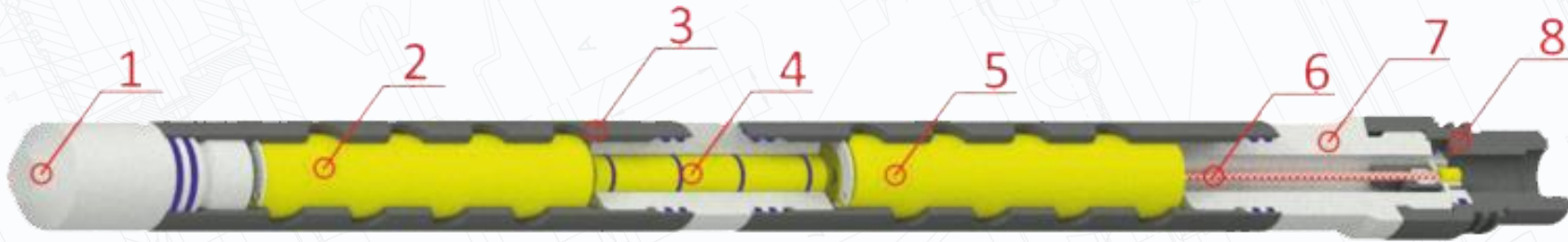

RELIABLE TRANSFER OF COMBUSTION BETWEEN FRAMES

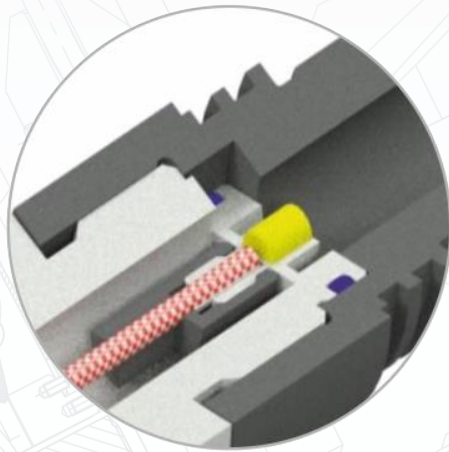

DETONATION FROM THE EXPLOSIVE HEAD



PERFORATED BODY

- 1** CONE
- 2** MAIN CHARGES
- 3** FRAME
- 4** THE INTERMEDIATE CHARGE
- 5** THE IGNITING CHARGE
- 6** DETONATING CORD
- 7** HEAD
- 8** ADAPTER

SUPPORT AT ALL STAGES



PLANNING

Selection of a candidate well for conducting gas dynamic impact together with the customer. Performance forecast. Design development.



ACCOMPLISHMENT

Author's control over compliance with the technology.



CONTROL

The operation of the pressure generator autonomous digital pressure cycles and the depth is controlled by gauges and redundant cracker devices.

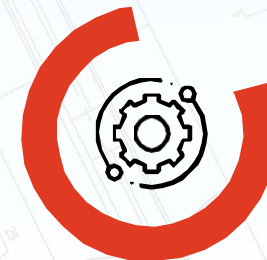

IMPACT MANAGEMENT

Recalculation of the number of generator charges, processing of the generator installation based on the results of the first descent.



EFFICIENCY ANALYSIS

Providing a report to the customer.

C RANGE OF APPLICATION

GAS-DYNAMIC FORMATION BREAKDOWN TECHNOLOGY BY GDK-170 GAS GENERATOR IS USED IN TERRIGENOUS AND CARBONATE RESERVOIR ROCKS:

- In production wells to increase the production
- In injection wells to enhance injectivity
- In exploration wells to clarify the potential of productive formations

STANDARD TREATMENT IS POSSIBLE IN THE FOLLOWING WELLS:



FLOW STRING
FROM 102 TO 178 MM
DEPTH FROM 250 TO 5000 M

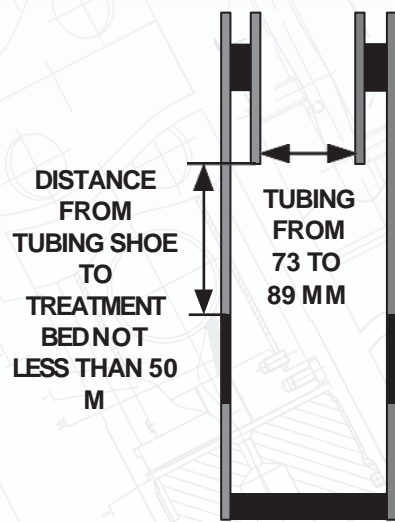

DISTANCE
FROM
TUBING SHOE
TO
TREATMENT
BED NOT
LESS THAN 50
M

TUBING
FROM
73 TO
89 MM

WELLS WITH THE BOTTOM
EQUIPMENT

DIAMETER
OF PACKER
PASSAGE
OPENING
NOT LESS
THAN 48 MM

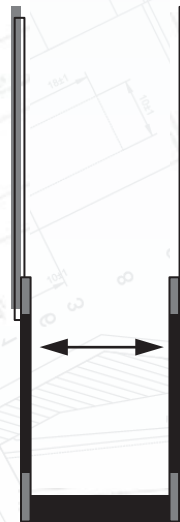

WELL WITH THE CEMENTED LINER
(DIAMETER OF LINER
FROM 102 MM)

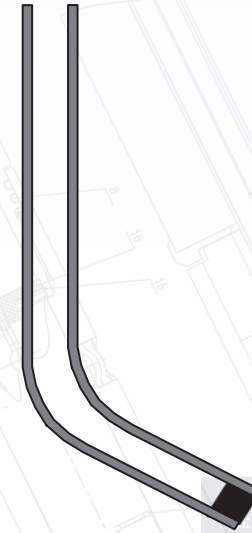

CONTROLLED DIRECTIONAL
WELLS (MAXIMAL DRIFT
ANGLE IS TILL 60 DEGREES)

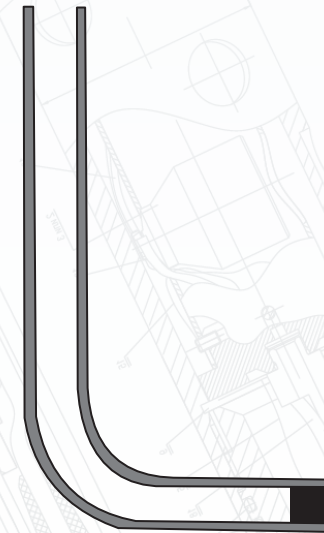

HORIZONTAL
WELLS (MAXIMAL
DRIFT
ANGLE IS TILL 90 DEGREES)

TECHNOLOGY PARAMETERS GDK-170

PARAMETER	SPECIFICATIONS					
TIPES SIZE	GDK-170-40	GDK-170-64*	GDK-170-56	GDK-170-68	GDK-170-87	GDK-170-105
OUTER DIAMETER, MM	40	64	56	68	87	105
MAXIMUM HYDROSTATIC PRESSURE, MPa	80	80	80	80	80	80
MAXIMUM TEMPERATURE, °C	170	170	170	170	170	170
NAME OF THE CHARGE	ZGD-40	ZGD-50	ZGD-56	ZGD-68	ZGD-88	ZGD-105
WEIGHT OF PER CHARGE, KG	0,9	1,6	1,9	2,9	5,1	7,1
DIAMETER OF PER CHARGE, MM	40	50	56	68	87	105
CHARGE LENGTH, MM	500	500	500	500	500	500
INNER DIAMETER, MM	16	16	16	16	16	16

*Pressure Generator , lowered by tubing

www.sts-geo.com

EFFICIENCY OF GAS DYNAMICS FRACTURING

The developed technology GDK-170 allows to achieve an increase in the productivity of the well stock with minimal financial and time costs.

Well category	Number of treatments using GDK-170 in 2025	Average duration of effect after GDK-170, months
PRODUCING WELLS FUND	302	12
INJECTION WELLS FUND	44	17

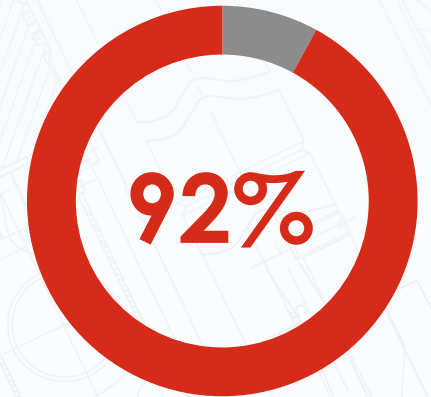
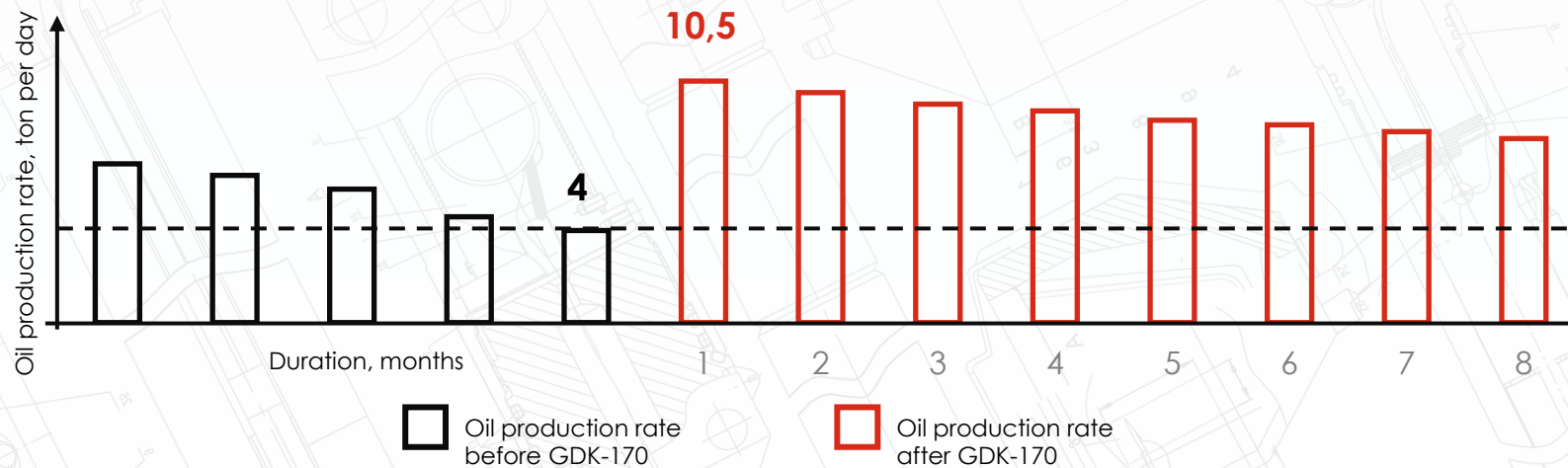

SUCCESSFUL TREATMENT AT THE PRODUCING WELLS FUND

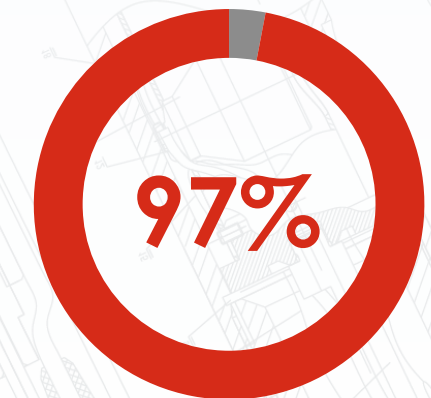

SUCCESSFUL TREATMENT AT THE INJECTION WELLS FUND

© COMPANY ACHIEVEMENTS

«STS-GeoService» LLC is one of the national leaders in the implementation of best practices to improve the efficiency of oil and gas field development, and also the developer of the unique patented design of the GDK-170

>3,5 MILLION TONS

TOTAL ADDITIONAL OIL PRODUCTION

INTERESTS OF OUR PARTNERS AND EMPLOYEES –
ARE OUR MAIN VALUES

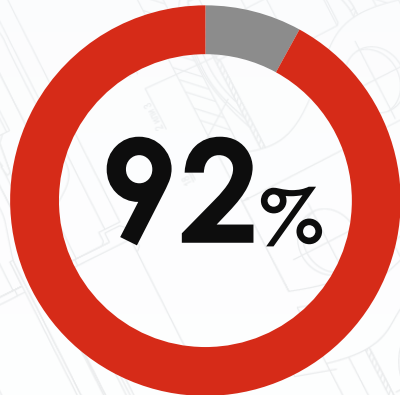

WORK SUCCESS

KEY PERFORMANCE
INDICATOR, ENTERPRISES

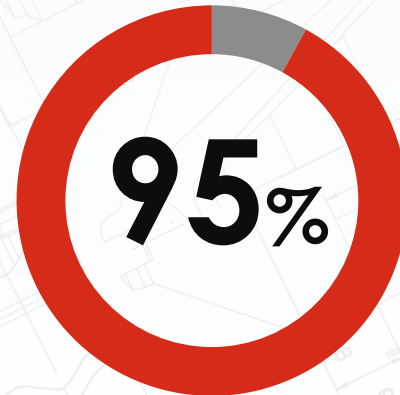

**CUSTOMER
CONFIDENCE INDEX**

DEMONSTRATING A POSITIVE
ATTITUDE TOWARDS THE
ORGANIZATION

>2800

TREATED WELLS

© ADVANTAGES OF THE GDK-170

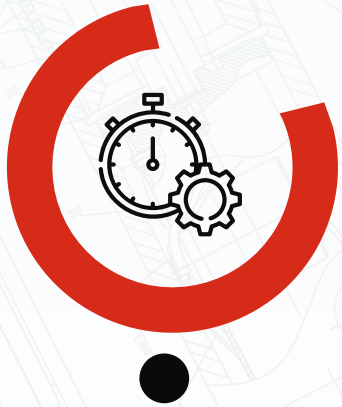

HIGH EFFICIENCY

The technology is effective as in a terrigenous as in a carbonate reservoirs



SWIFTY AND MOBILITY

Possibility of prompt delivery by air. Mobilization for work during the day



ECONOMIC EFFECTIVENESS

The payback of the technology is 2 – 6 months



MANUFACTURABILITY

Ability to work through tubing, in horizontal wells



ENVIRONMENTAL FRIENDLY

Does not pollute the environment

COMPLEX PERFORATOR-GENERATOR «URAGAN»

Complex stimulation technology allows to enter a productive formation and increase the oil flow for one round trip

APPLICATION OF THE CPG «URAGAN»:

- Construction: vertical, horizontal, directional wells.
- Purpose: production well, injection well and wild-cats.
- Layer lithology: terrigenous and carbonate reservoirs .

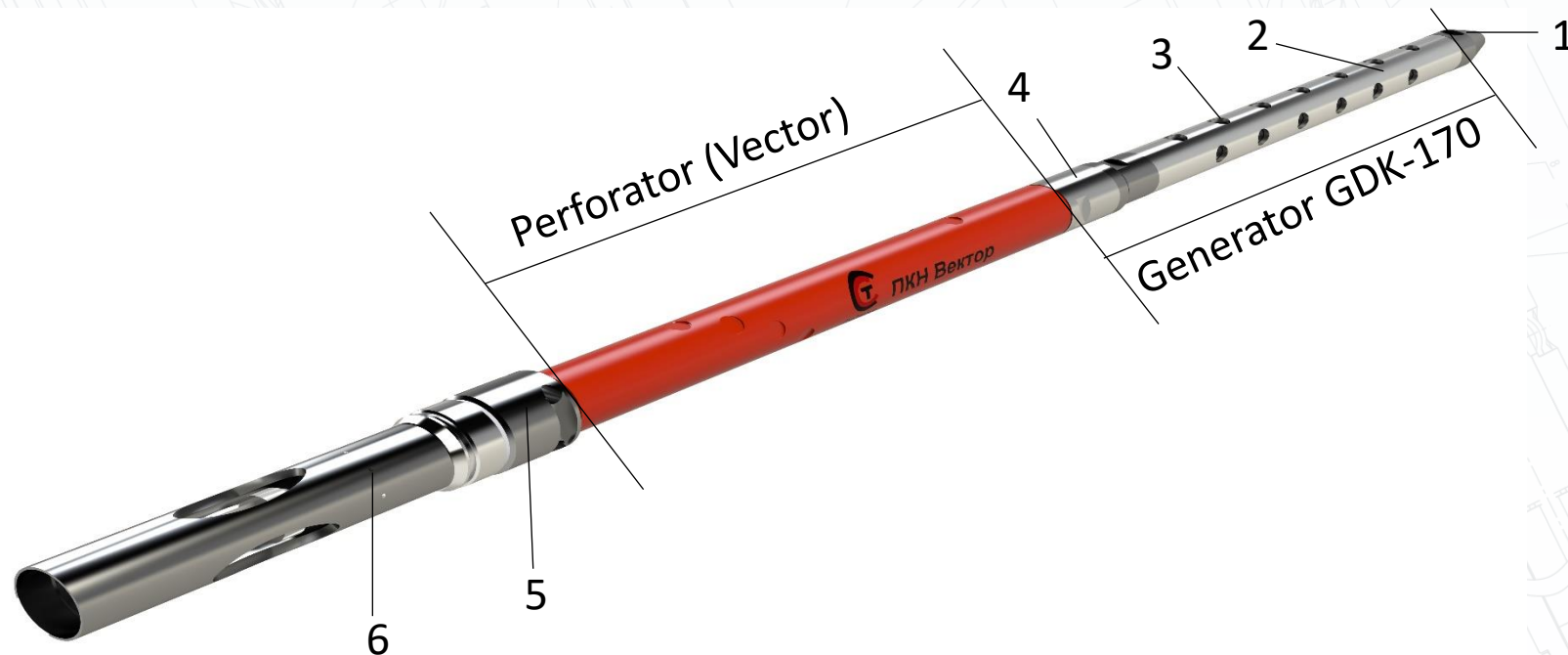

- 1 CONE
- 2 MAIN CHARGE
- 3 ACTIVE CHARGE
- 4 DETONATION TRANSFER UNIT
- 5 TRANSMISSION OF DETONATION
- 6 EXPLOSIVE HEAD

© THE PRINCIPLE OF WORK OF CPG «URAGAN»

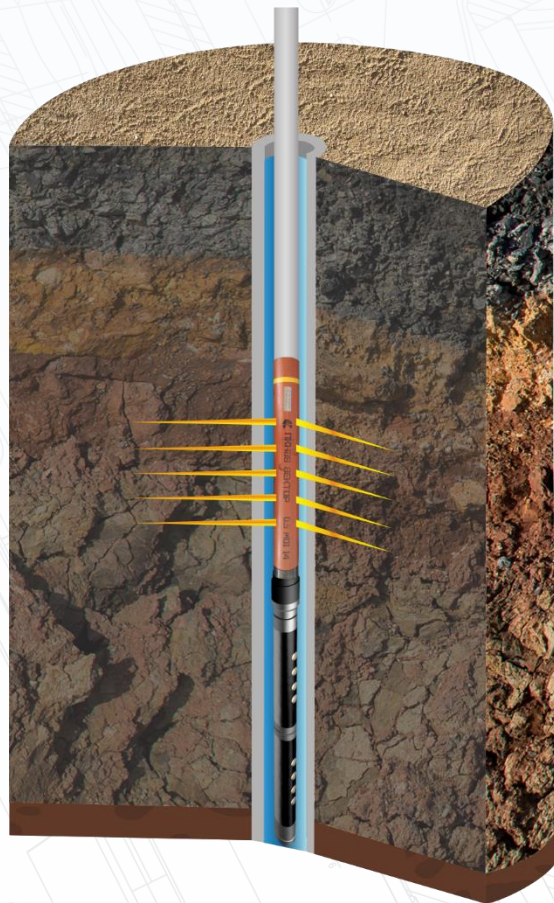

Perforator shooting – creation of perforation channels

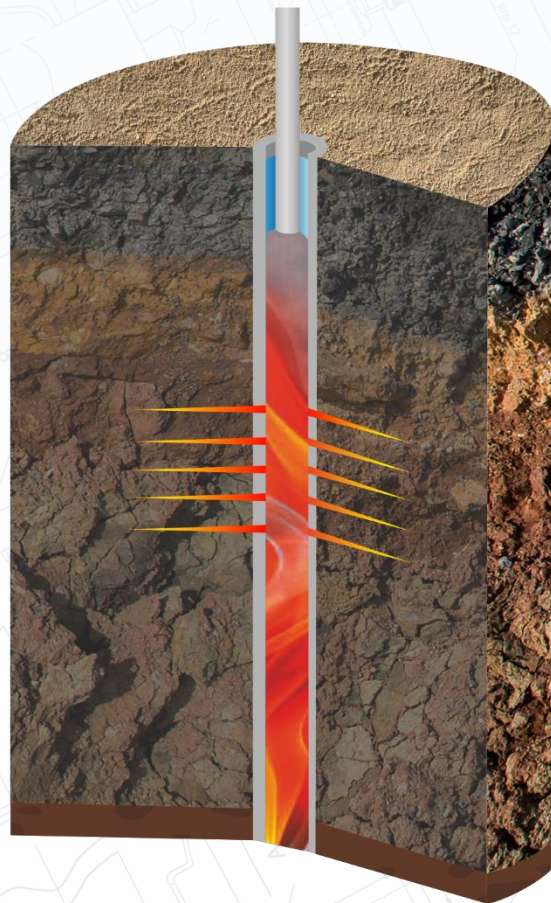

Generation shooting – the intrusion of combustion products charges into formation

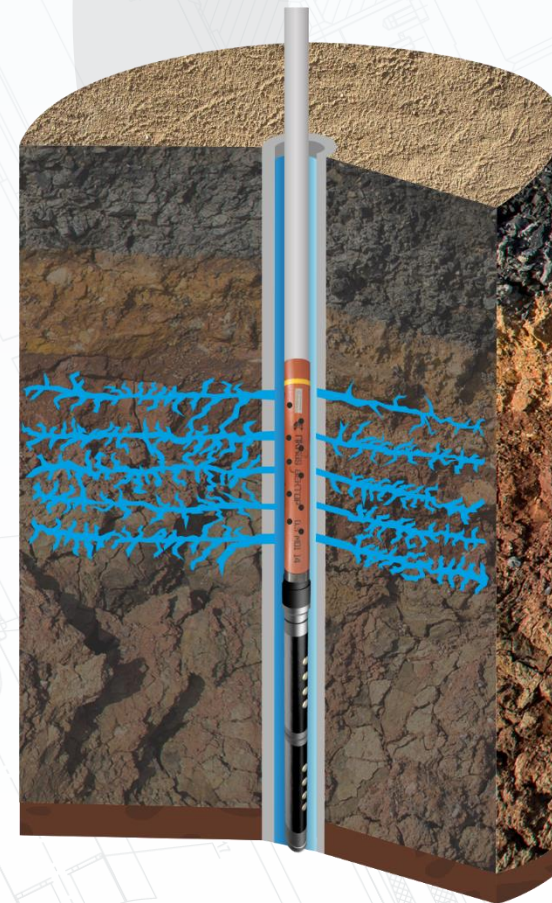

Network cracks creation

© INTEGRATED IMPACT WITH GDK-170

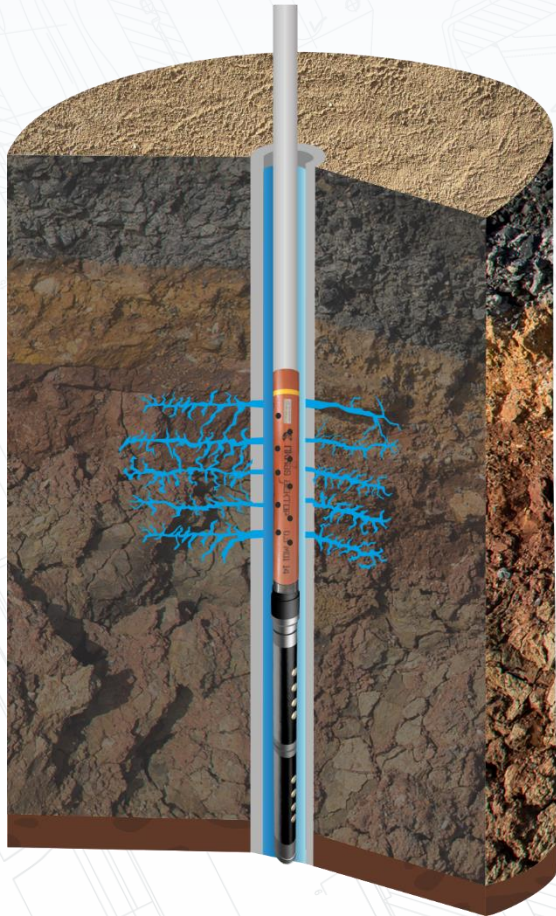

CPG «URAGAN» -Network cracks creation

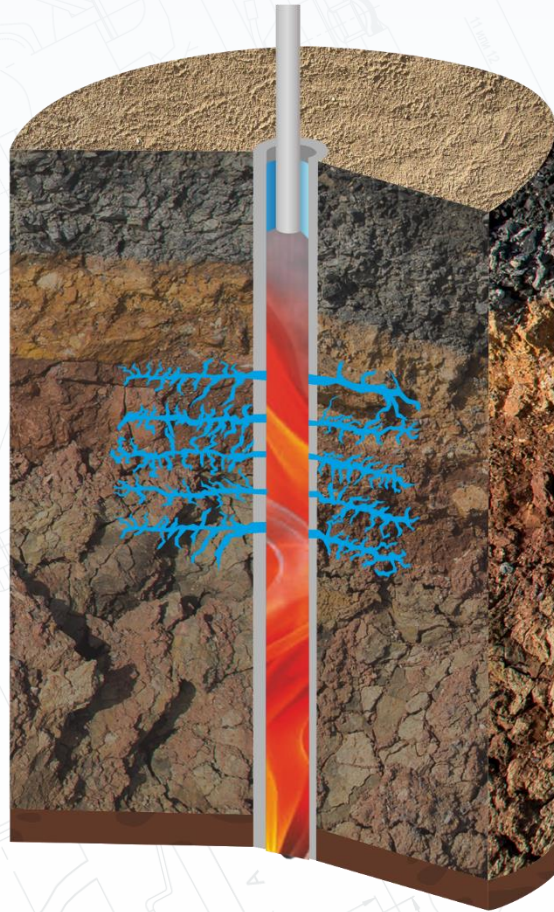

Crack development

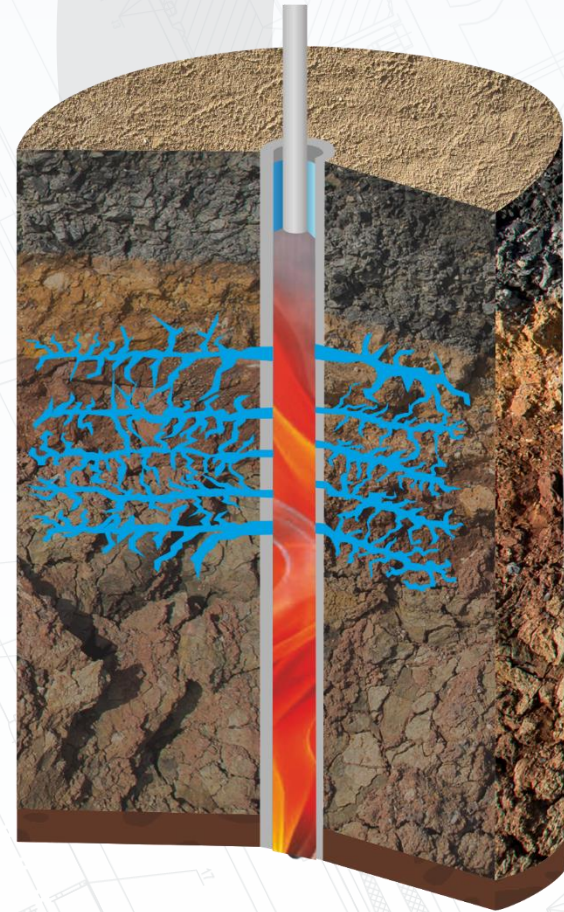

Residual fractures after gas-dynamic fracturing

© ADVANTAGES OF CPG «URAGAN»



UNIQUENESS

The first perforator-generator that allows to make gas-dynamic fracturing



UNIVERSALITY

The ability to work in both horizontal and directional wells



EFFICIENCY AND PROFITABILITY

High technological efficiency. Reducing material costs for geological and technical measures



FLEXIBILITY

Possibility of combining perforation systems of any standard size with powder charges

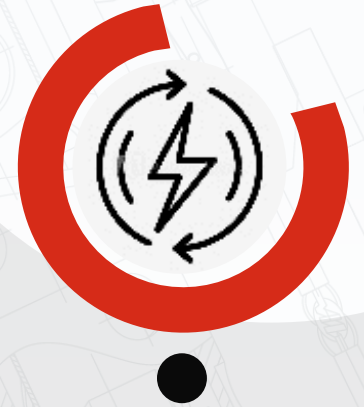

POWER

The most powerful perforator-generator

© OUR PARTNERS



UZBEKNEFTEGAZ



SOCAR



ЛУКОЙЛ
НЕФТЯНАЯ КОМПАНИЯ



ГАЗПРОМ
НЕФТЬ



РОСНЕФТЬ



ГАЗПРОМ



Schlumberger



www.sts-geo.com

ATTACHMENT 1

GDK TREATMENT EFFECTIVENESS IN PRODUCING WELLS

№	CATEGORY	FORMATION	PARAMETRS	MODE BEFORE REPAIR	PUT ON PRODUCTION	DURATION OF THE EFFECT ON, MONTH
1	PRODUCING	BC4-1(1-2)	Q flowrate	13	58	27,5
			Q oil flow rate	1,5	7,2	
			Water cut, %	87,2	85,6	
			W level,m	1951	1225	
2	PRODUCING	BC4-1(1-2)	Q flowrate	12	21	26,2
			Q oil flow rate	2,1	9,2	
			Water cut, %	79,9	48,3	
			W level,m	1915	1708	
3	PRODUCING	BC4-1(1-2)	Q flowrate	15	22	34
			Q oil flow rate	4,4	12,1	
			Water cut, %	66,4	36,0	
			W level,m	1797	1581	
4	PRODUCING	V10	Q flowrate	2	14	29
			Q oil flow rate	1,7	11,9	
			Water cut, %	0,0	0,0	
			W level,m	1215	950	
5	PRODUCING	UC2/1	Q flowrate	6,42	20,8	19,7
			Q oil flow rate	1,64	6,5	
			Water cut, %	70,74	64,4	
			W level,m	792	1674	
6	PRODUCING	ASH1-5	Q flowrate	6	29	21,7
			Q oil flow rate	1,1	12,5	
			Water cut, %	78,1	50,0	
			W level,m	1687	1635	
7	PRODUCING	UC2/1	Q flowrate	4,9	29	22,4
			Q oil flow rate	1,4	11,4	
			Water cut, %	66,4	41,9	
			W level,m	1738	1937	

№	CATEGORY	FORMATION	OPERATING PARAMETS BEFORE GDK		OPERATING PARAMETS AFTER GDK		DURATION OF EFFECT, MONTH
			Q flow rate, m3/day	P pw, psi	Q flow rate, m3/day	P pw, psi	
1	INJECTION	UC2/1	10	189	170	189	23,8
2	INJECTION	UC2/1	35	250	160	237	15,6
3	INJECTION	ASH1-5	5	145	36	149	25,1
4	INJECTION	UC2/1; UC2/2	10	162	150	164	28
5	INJECTION	UC2/1; UC2/2	OIL		100	147	21,4
6	INJECTION	UC2/1	2	227	95	198	19,3
7	INJECTION	BC10	370	70	420	69	22,9
8	INJECTION	AC5	3	163	75	170	18,0
9	INJECTION	BC10	0	140	60	140	23,2
10	INJECTION	BC4/1(1-2)	10	138	99	141	17,5

ATTACHMENT 3

EXPERIANCE OF APPLICATION OF GDK-170 ON A HORIZONTAL FUND

№	CATEGORY	FORMATION	PERFORATION INTERVAL (FILTER)	PERFORATION TYPE (FILTER)	MODE PARAMETR	BEFORE GDK	AFTER GDK	MODE CHANGE
1	EXPLORATION	YA	3257-3278	Perforation	Q flow rate	13	156	143,0
					Q oil flow rate	10,9	131,0	120,1
					Water cut, %	0,1	0,1	0,0
					W level,m	1417	1435	18,0
2	PRODUCING	NKH 3-7	2213,98-2313,5 2474,28-2623,25	FS Filter	Q flow rate	157	252	95,0
					Q oil flow rate	76,9	115,0	38,1
					Water cut, %	46,0	56,0	10,0
					W level,m	1505	1371	-134,0
3	PRODUCING	2BP6	2903-3433	FS Filter	Q flow rate	69	121	52,0
					Q oil flow rate	6,0	14,2	8,2
					Water cut, %	90,0	86,0	-4,0
					W level,m	2600	1300	-1300,0
4	PRODUCING	NKH-1	3192-3954	FOK-II-300x3000x2-OTM	Q flow rate	19	39	20,0
					Q oil flow rate	15	27,0	11,8
					Water cut, %	3,0	16,0	13,0
					W level,m	2370	2118	-252,0
5	INJECTION	PK1-3	1537-1873	FC-114	Inje flow rate	79,5	153	73,5
					Bump pressure	37,0	37,0	0,0
6	PRODUCING	YA	3170-3675	Open hole	Q flow rate	16,3	25	8,2
					Q oil flow rate	13,0	20,8	7,8
					Water cut, %	0,0	0,0	0,0
					W level,m	0	0	0,0

STS-GEOSERVICE

THE SECOND BREATH OF WELLS

 www.sts-geo.com

 **+7 (495) 517-53-52**

 **+7 (496) 467-39-27**

 reception@sts-geo.com

 Russia, 140100, Moscow reg, r.
Ramenskoe, 64 Moskvoreckaya
street

www.sts-geo.com

